

Square 40x40mm

fastening types:
suspension by customer

with insert at both ends (50mm)
max. span of tile 1600 mm

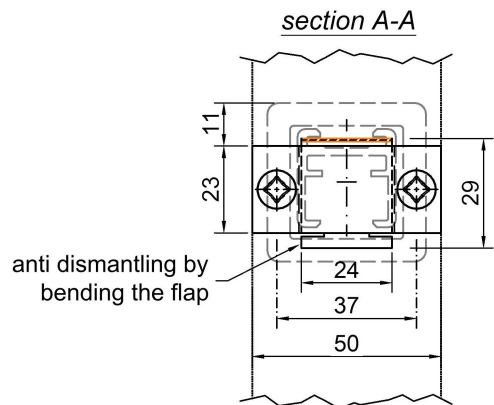
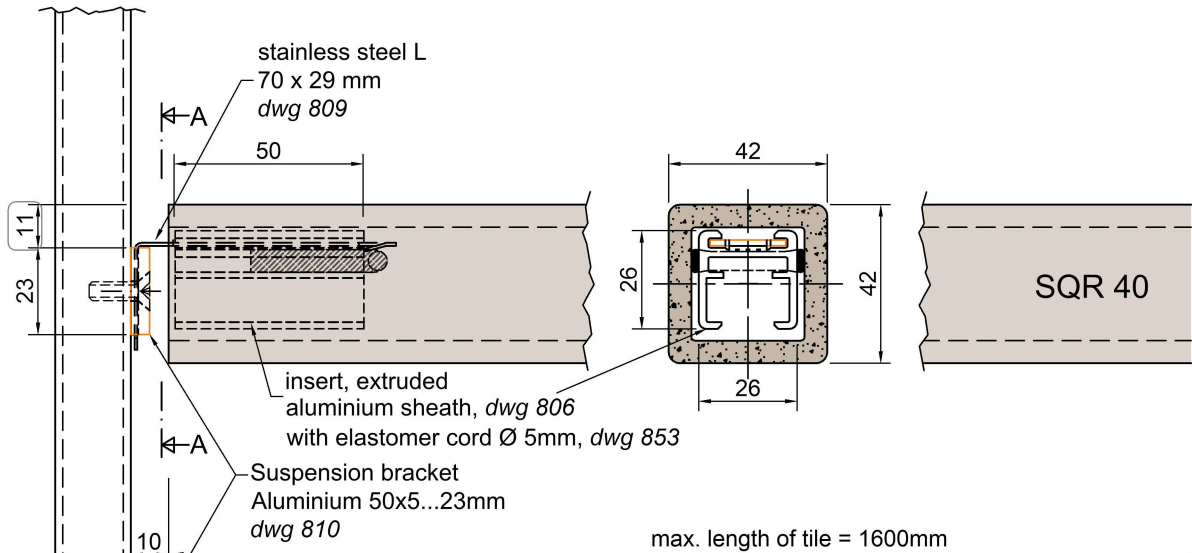

top view

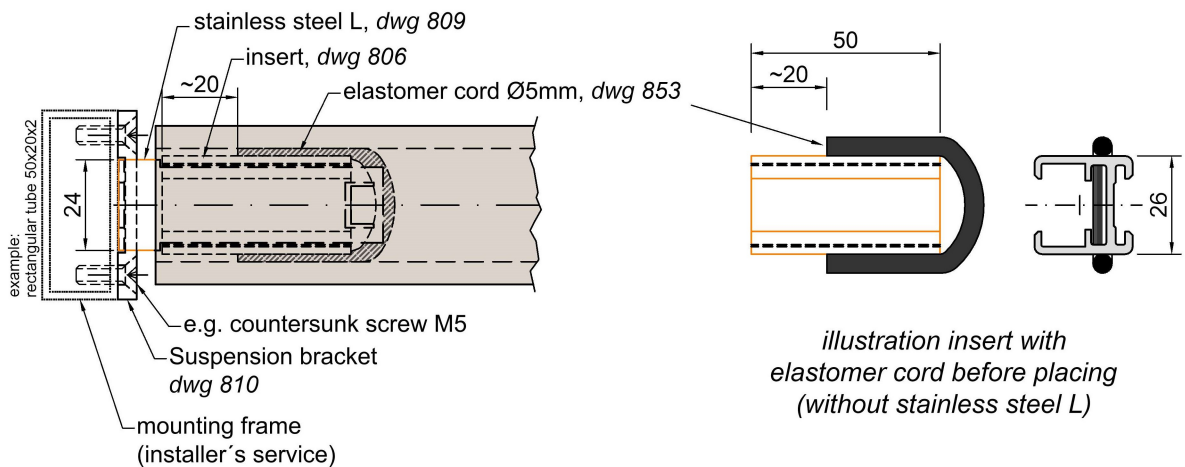

! The allocation of weight is subject to the principal's liability
and underlies job-site verification by a static expert.